

Estlcam Terminal Adapter "Light"

The "Light" version of the "Estlcam Terminal Adapter" is a low cost implementation offering just the most basic features.

- Check the "Main Schematic" folder to learn more about all possible features and options.
- Make sure to program AVR64DB64 Flash, EEPROM and Fuses with the files and instructions provided in the "Bootloader" folder!

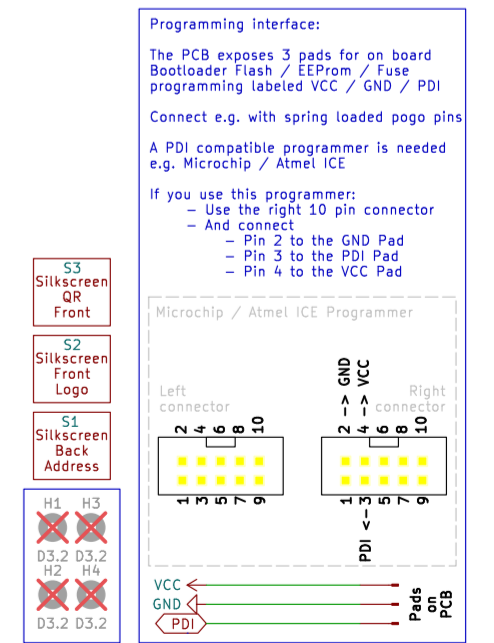
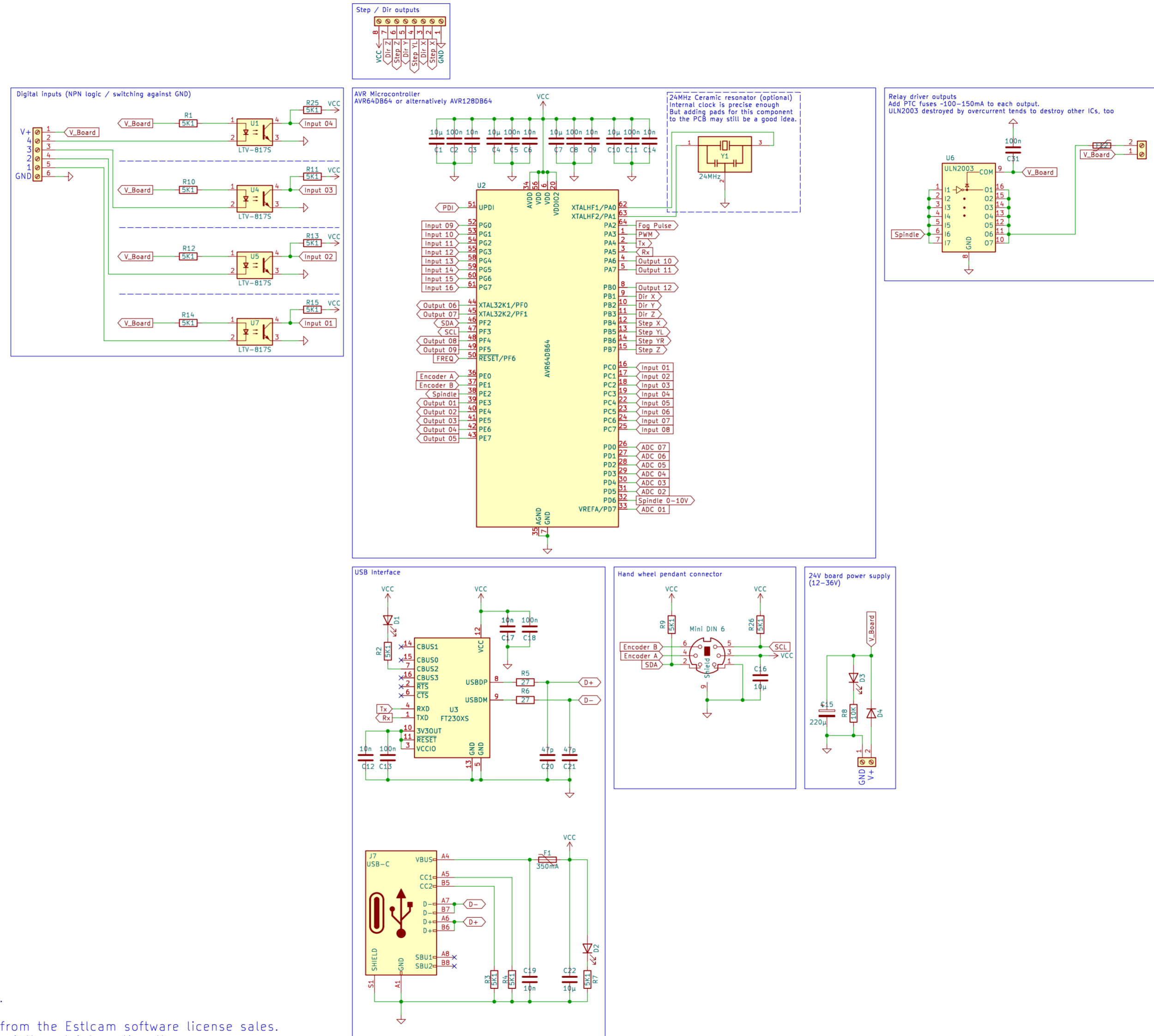

The Estlcam hardware designs are free:

- You are allowed to manufacture and sell Estlcam compatible hardware.
- Actually I really appreciate it if you do so:
 - I'm a hardware and software development guy and get my income from the Estlcam software license sales.
 - I'm not much interested in manufacturing and hardware sales, especially not internationally.

There are only 2 conditions:

- 1: Your product = your responsibility.
 - Do everything at your own risk and don't hold me liable.
 - Ensuring the products compliance to your intended markets laws and regulations is up to you.
- 2: Put your company name and address on the finished product:
 - Customers must be able to tell who manufactured the product.
 - You are allowed to use the Estlcam logo - this is OK.

Please keep in mind that while personal use and modifications are welcome I simply don't have enough time to assist with personal projects if you run into issues.
 This project is mainly for commercial manufacturing and sales.

Estlcam / Christian Knütt

Sheet: /
 File: Terminal Light.kicad_sch

Title:

Size: A2 Date:

Rev:

KiCad E.D.A. B.0.1

Id: 1/1